

TJA1021

LIN 2.0/SAE J2602 transceiver

Rev. 03 — 8 October 2007

Product data sheet

1. General description

The TJA1021 is the interface between the Local Interconnect Network (LIN) master/slave protocol controller and the physical bus in a LIN. It is primarily intended for in-vehicle sub-networks using baud rates from 1 kBd up to 20 kBd and is LIN 2.0/SAE J2602 compliant. The TJA1021 is pin-to-pin compatible with the TJA1020 and improved on ElectroStatic Discharge (ESD).

The transmit data stream of the protocol controller at the transmit data input (TXD) is converted by the TJA1021 into a bus signal with optimized slew rate and wave shaping to minimize ElectroMagnetic Emission (EME). The LIN bus output pin is pulled HIGH via an internal termination resistor. For a master application an external resistor in series with a diode should be connected between pin INH or pin V_{BAT} and pin LIN. The receiver detects the data stream at the LIN bus input pin and transfers it via pin RXD to the microcontroller.

In sleep mode the power consumption of the TJA1021 is very low. In failure modes the power consumption is reduced to a minimum.

2. Features

2.1 General

- LIN 2.0/SAE J2602 compliant
- Baud rate up to 20 kBd
- Very low ElectroMagnetic Emission (EME)
- High ElectroMagnetic Immunity (EMI)
- Passive behavior in unpowered state
- Input levels compatible with 3.3 V and 5 V devices
- Integrated termination resistor for LIN slave applications
- Wake-up source recognition (local or remote)
- Supports K-line like functions
- Pin-to-pin compatible with TJA1020

2.2 Low power management

- Very low current consumption in sleep mode with local and remote wake-up

2.3 Protections

- High ESD robustness: ± 6 kV according to IEC 61000-4-2 for pins LIN, V_{BAT} and WAKE_N
- Transmit data (TXD) dominant time-out function

- Bus terminal and battery pin protected against transients in the automotive environment (ISO 7637)
- Bus terminal short-circuit proof to battery and ground
- Thermally protected

3. Quick reference data

Table 1. Quick reference data

$V_{BAT} = 5.5\text{ V to }27\text{ V}$; $T_{vj} = -40\text{ }^{\circ}\text{C to }+150\text{ }^{\circ}\text{C}$; $R_{L(LIN-VBAT)} = 500\ \Omega$; all voltages are defined with respect to ground; positive currents flow into the IC; typical values are given at $V_{BAT} = 12\text{ V}$; unless otherwise specified.[\[1\]](#)

Symbol	Parameter	Conditions	Min	Typ	Max	Unit
V_{BAT}	supply voltage on pin V_{BAT}	with respect to GND	-0.3		+40	V
I_{BAT}	supply current on pin V_{BAT}	sleep mode ($V_{LIN} = V_{BAT}$; $V_{WAKE_N} = V_{BAT}$; $V_{TXD} = 0\text{ V}$; $V_{SLP_N} = 0\text{ V}$)	2	7	10	μA
		standby mode; bus recessive ($V_{INH} = V_{BAT}$; $V_{LIN} = V_{BAT}$; $V_{WAKE_N} = V_{BAT}$; $V_{TXD} = 0\text{ V}$; $V_{SLP_N} = 0\text{ V}$)	150	450	1000	μA
		standby mode; bus dominant ($V_{BAT} = 12\text{ V}$; $V_{INH} = 12\text{ V}$; $V_{LIN} = 0\text{ V}$; $V_{WAKE_N} = 12\text{ V}$; $V_{TXD} = 0\text{ V}$; $V_{SLP_N} = 0\text{ V}$)	300	800	1200	μA
		normal mode; bus recessive ($V_{INH} = V_{BAT}$; $V_{LIN} = V_{BAT}$; $V_{WAKE_N} = V_{BAT}$; $V_{TXD} = 5\text{ V}$; $V_{SLP_N} = 5\text{ V}$)	300	800	1600	μA
V_{LIN}	voltage on pin LIN	normal mode; bus dominant ($V_{BAT} = 12\text{ V}$; $V_{INH} = 12\text{ V}$; $V_{WAKE_N} = 12\text{ V}$; $V_{TXD} = 0\text{ V}$; $V_{SLP_N} = 5\text{ V}$)	1	2	4	mA
		with respect to GND, V_{BAT} and V_{WAKE_N}	-40	-	+40	V
T_{vj}	virtual junction temperature		[2] -40	-	+150	$^{\circ}\text{C}$

- [1] All parameters are guaranteed by design over the virtual junction temperature range. Products are 100 % tested at 125 °C ambient temperature on wafer level (pre-testing). Cased products are 100 % tested at 25 °C ambient temperature (final testing). Both pre-testing and final testing use correlated test conditions to cover the specified temperature and power supply voltage range.
- [2] Junction temperature in accordance with IEC 60747-1. An alternative definition is: $T_{vj} = T_{amb} + P \times R_{th(vj-a)}$, where $R_{th(vj-a)}$ is a fixed value. The rating for T_{vj} limits the allowable combinations of power dissipation (P) and ambient temperature (T_{amb}).

4. Ordering information

Table 2. Ordering information

Type number ^[1]	Package		Version
	Name	Description	
TJA1021T/10; TJA1021T/20	SO8	plastic small outline package; 8 leads; body width 3.9 mm	SOT96-1

- [1] TJA1021T/20: for the normal slope version which supports baud rates up to 20 kBd;
TJA1021T/10: for the low slope version which supports baud rates up to 10.4 kBd (SAE J2602).

5. Block diagram

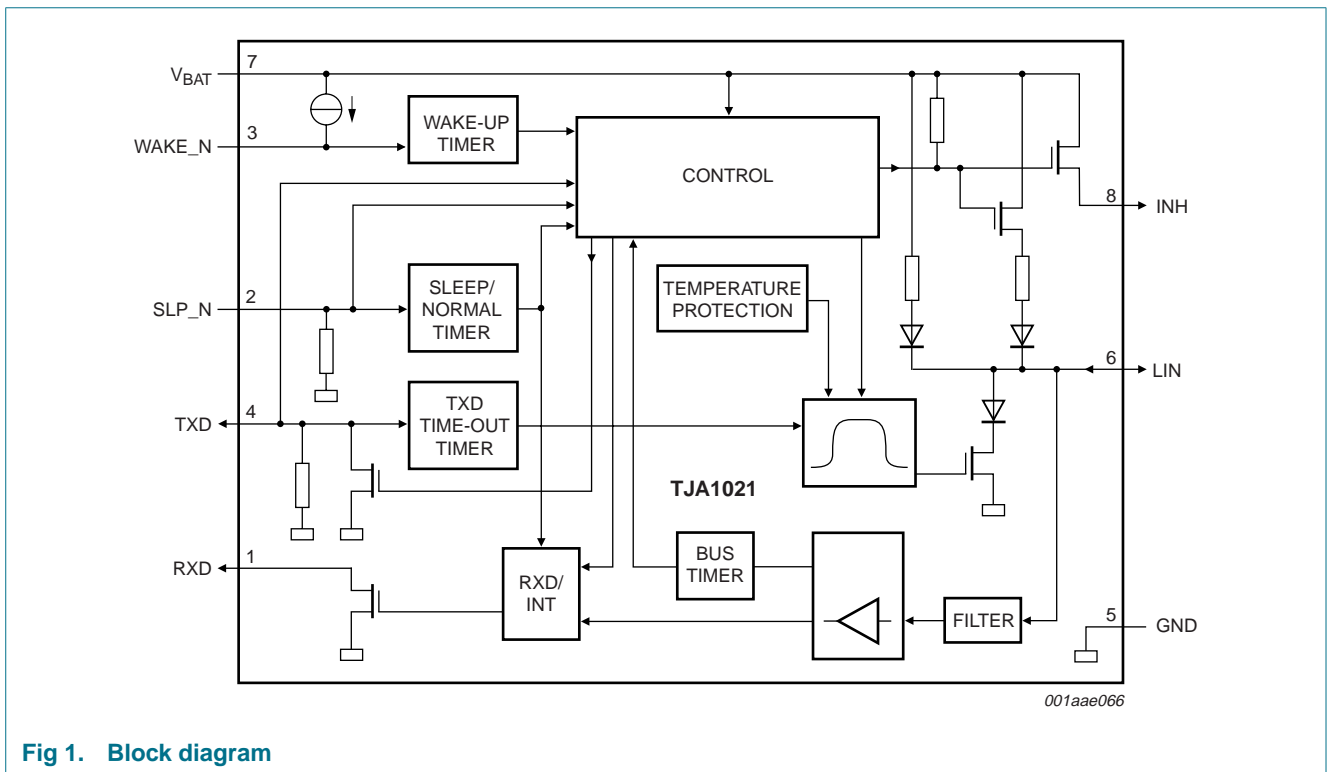

Fig 1. Block diagram

6. Pinning information

6.1 Pinning

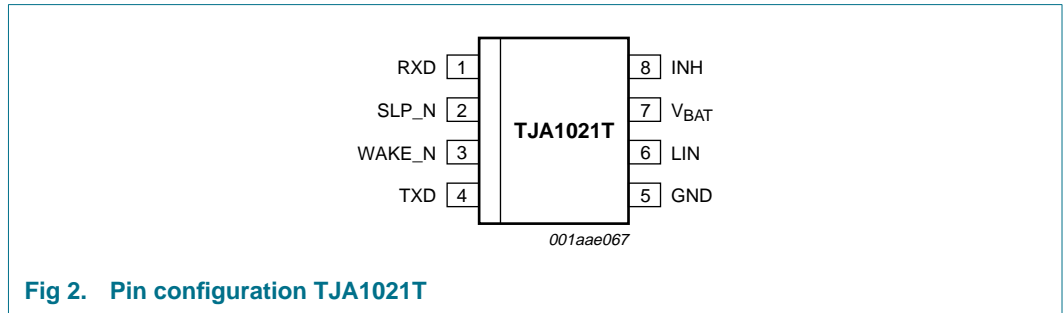

Fig 2. Pin configuration TJA1021T

6.2 Pin description

Table 3. Pin description

Symbol	Pin	Description
RXD	1	receive data output (open-drain); active LOW after a wake-up event
SLP_N	2	sleep control input (active LOW); controls inhibit output; resets wake-up source flag on TXD and wake-up request on RXD
WAKE_N	3	local wake-up input (active LOW); negative edge triggered
TXD	4	transmit data input; active LOW output after a local wake-up event
GND	5	ground
LIN	6	LIN bus line input/output
V _{BAT}	7	battery supply
INH	8	battery related inhibit output for controlling an external voltage regulator; active HIGH after a wake-up event

7. Functional description

The TJA1021 is the interface between the LIN master/slave protocol controller and the physical bus in a Local Interconnect Network (LIN). The TJA1021 is LIN 2.0/SAE J2602 compliant and provides optimum ElectroMagnetic Compatibility (EMC) performance due to wave shaping of the LIN output.

The /20 version of the TJA1021 is optimized for the maximum specified LIN transmission speed of 20 kBd; the /10 version of the TJA1021 is optimized for the LIN transmission speed of 10.4 kBd as specified by the SAE J2602.

7.1 Operating modes

The TJA1021 provides a mode of normal operation, an intermediate mode, a power-up mode and a very-low-power mode. [Figure 3](#) shows the state diagram.

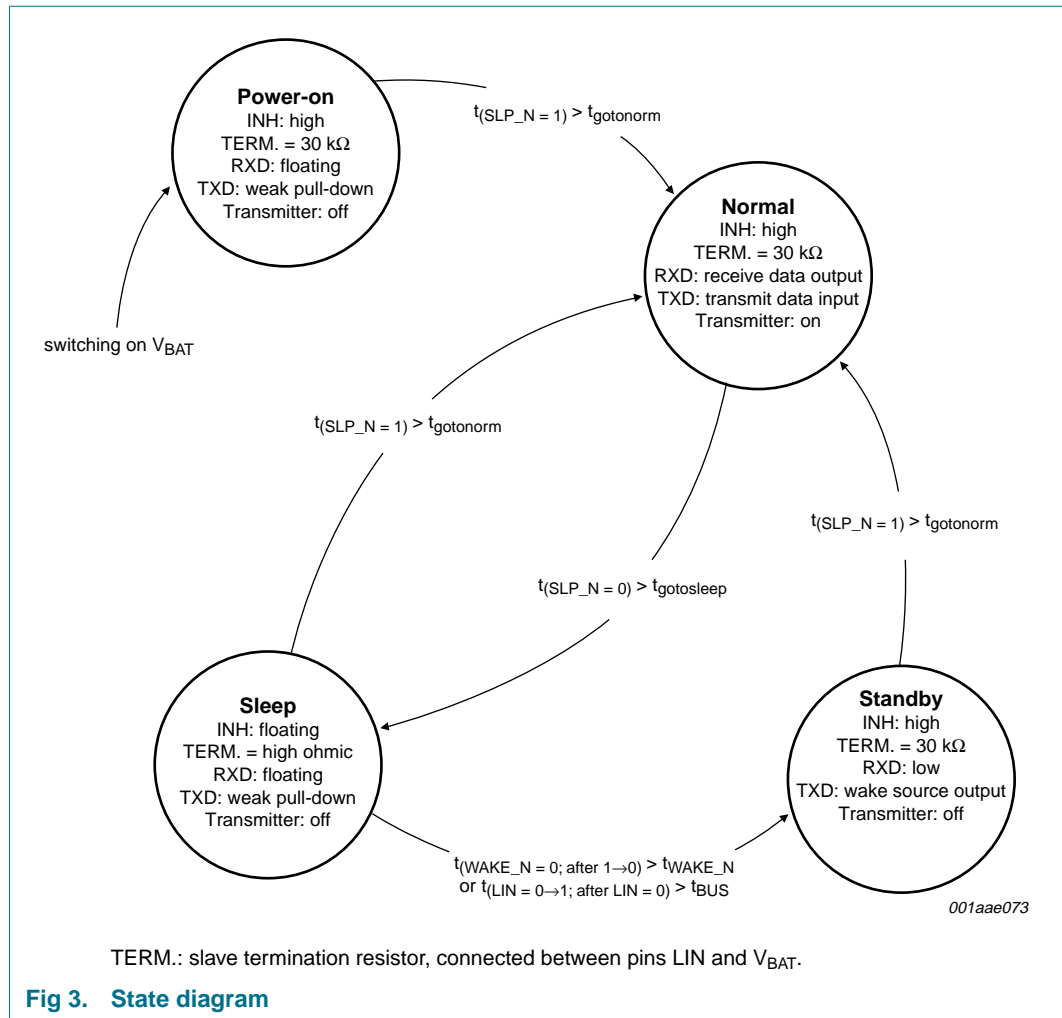

Fig 3. State diagram

Table 4. Operating modes

Mode	SLP_N	TXD (output)	RXD	INH	Transmitter	Remarks
Sleep	0	weak pull-down	floating	floating	off	no wake-up request detected
Standby ^[1]	0	weak pull-down if remote wake-up; strong pull-down if local wake-up ^[2]	LOW ^[3]	HIGH	off	wake-up request detected; in this mode the microcontroller can read the wake-up source: remote or local wake-up
Normal mode	1	HIGH: recessive state LOW: dominant state	HIGH: recessive state LOW: dominant state	HIGH	normal mode	^[2] ^[3] ^[4]
Power-on mode	0	weak pull-down	floating	HIGH	off	^[5]

[1] Standby mode is entered automatically upon any local or remote wake-up event during sleep mode. Pin INH and the 30 kΩ termination resistor at pin LIN are switched on.

[2] The internal wake-up source flag (set if a local wake-up did occur and fed to pin TXD) will be reset after a positive edge on pin SLP_N.

[3] The wake-up interrupt (on pin RXD) is released after a positive edge on pin SLP_N.

- [4] Normal mode is entered after a positive edge on SLP_N. As long as TXD is LOW, the transmitter is off. In the event of a short-circuit to ground on pin TXD, the transmitter will be disabled.
- [5] Power-on mode is entered after switching on V_{BAT}.

7.2 Sleep mode

This mode is the most power-saving mode of the TJA1021. Despite its extreme low current consumption, the TJA1021 can still be woken up remotely via pin LIN, or woken up locally via pin WAKE_N, or activated directly via pin SLP_N. Filters at the inputs of the receiver (LIN), of pin WAKE_N and of pin SLP_N prevent unwanted wake-up events due to automotive transients or EMI. All wake-up events have to be maintained for a certain time period ($t_{\text{wake(dom)LIN}}$, $t_{\text{wake(dom)WAKE_N}}$ and t_{gotonorm}).

Sleep mode is initiated by a falling edge on pin SLP_N in normal mode. To enter sleep mode successfully (INH becomes floating), the sleep command (pin SLP_N = LOW) must be maintained for at least $t_{\text{gotosleep}}$.

In sleep mode the internal slave termination between pins LIN and V_{BAT} is disabled to minimize the power dissipation in the event that pin LIN is short-circuited to ground. Only a weak pull-up between pins LIN and V_{BAT} is present.

Sleep mode can be activated independently from the actual level on pin LIN, pin TXD or pin WAKE_N. So it is guaranteed that the lowest power consumption is achievable even in case of a continuous dominant level on pin LIN or a continuous LOW on pin WAKE_N.

When V_{BAT} drops below the power-on-reset threshold $V_{\text{th(POR)L}}$, the TJA1021 enters sleep mode.

7.3 Standby mode

Standby mode is entered automatically whenever a local or remote wake-up occurs while the TJA1021 is in sleep mode. These wake-up events activate pin INH and enable the slave termination resistor at the pin LIN. As a result of the HIGH condition on pin INH the voltage regulator and the microcontroller can be activated.

Standby mode is signalled by a LOW-level on pin RXD which can be used as an interrupt for the microcontroller.

In standby mode (pin SLP_N is still LOW), the condition of pin TXD (weak pull-down or strong pull-down) indicates the wake-up source: weak pull-down for a remote wake-up request and strong pull-down for a local wake-up request.

Setting pin SLP_N HIGH during standby mode results in the following events:

- An immediate reset of the wake-up source flag; thus releasing the possible strong pull-down at pin TXD before the actual mode change (after t_{gotonorm}) is performed
- A change into normal mode if the HIGH level on pin SLP_N has been maintained for a certain time period (t_{gotonorm})
- An immediate reset of the wake-up request signal on pin RXD

7.4 Normal mode

In normal mode the TJA1021 is able to transmit and receive data via the LIN bus line. The receiver detects the data stream at the LIN bus input pin and transfers it via pin RXD to the microcontroller (see [Figure 1](#)): HIGH at a recessive level and LOW at a dominant level on the bus. The receiver has a supply-voltage related threshold with hysteresis and an integrated filter to suppress bus line noise. The transmit data stream of the protocol controller at the TXD input is converted by the transmitter into a bus signal with optimized slew rate and wave shaping to minimize EME. The LIN bus output pin is pulled HIGH via an internal slave termination resistor. For a master application an external resistor in series with a diode should be connected between pin INH or V_{BAT} on one side and pin LIN on the other side (see [Figure 6](#)).

Being in sleep, standby or power-up mode, the TJA1021 enters normal mode whenever a HIGH level on pin SLP_N is maintained for a time of at least $t_{gotonorm}$.

The TJA1021 switches to sleep mode in case of a LOW-level on pin SLP_N, maintained for a time of at least $t_{gotosleep}$.

7.5 Wake-up

When V_{BAT} exceeds the power-on-reset threshold voltage $V_{th(POR)H}$, the TJA1021 enters power-on mode. Though the TJA1021 is powered-up and INH is HIGH, both the transmitter and receiver are still inactive. If SLP_N = 1 for $t > t_{gotonorm}$, the TJA1021 enters normal mode.

There are three ways to wake-up a TJA1021 which is in sleep mode:

1. Remote wake-up via a dominant bus state of at least $t_{wake(dom)LIN}$
2. Local wake-up via a negative edge at pin WAKE_N
3. Mode change (pin SLP_N is HIGH) from sleep mode to normal mode

7.6 Remote and local wake-up

A falling edge at pin LIN followed by a LOW level maintained for a certain time period ($t_{wake(dom)LIN}$) and a rising edge at pin LIN respectively (see [Figure 4](#)) results in a remote wake-up. It should be noted that the time period $t_{wake(dom)LIN}$ is measured either in normal mode while TXD is HIGH, or in sleep mode irrespective of the status of pin TXD.

A falling edge at pin WAKE_N followed by a LOW level maintained for a certain time period ($t_{wake(dom)WAKE_N}$) results in a local wake-up. The pin WAKE_N provides an internal pull-up towards pin V_{BAT} . In order to prevent EMI issues, it is recommended to connect an unused pin WAKE_N to pin V_{BAT} .

After a local or remote wake-up, pin INH is activated (it goes HIGH) and the internal slave termination resistor is switched on. The wake-up request is indicated by a LOW active wake-up request signal on pin RXD to interrupt the microcontroller.

7.7 Wake-up via mode transition

It is also possible to set pin INH HIGH with a mode transition towards normal mode via pin SLP_N. This is useful for applications with a continuously powered microcontroller.

7.8 Wake-up source recognition

The TJA1021 can distinguish between a local wake-up request on pin WAKE_N and a remote wake-up request via a dominant bus state. The wake-up source flag is set in case the wake-up request was a local one. The wake-up source can be read on pin TXD in the standby mode. If an external pull-up resistor on pin TXD to the power supply voltage of the microcontroller has been added, a HIGH level indicates a remote wake-up request (weak pull-down at pin TXD) and a LOW level indicates a local wake-up request (strong pull-down at pin TXD; much stronger than the external pull-up resistor).

The wake-up request flag (signalled on pin RXD) as well as the wake-up source flag (signalled on pin TXD) are reset immediately after the microcontroller sets pin SLP_N HIGH.

7.9 TXD dominant time-out function

A TXD dominant time-out timer circuit prevents the bus line from being driven to a permanent dominant state (blocking all network communication) if pin TXD is forced permanently LOW by a hardware and/or software application failure. The timer is triggered by a negative edge on pin TXD. If the duration of the LOW-level on pin TXD exceeds the internal timer value ($t_{to(dom)TXD}$), the transmitter is disabled, driving the bus line into a recessive state. The timer is reset by a positive edge on pin TXD.

7.10 Fail-safe features

Pin TXD provides a pull-down to GND in order to force a predefined level on input pin TXD in case the pin TXD is unsupplied.

Pin SLP_N provides a pull-down to GND in order to force the transceiver into sleep mode in case the pin SLP_N is unsupplied.

Pin RXD is set floating in case of lost power supply on pin V_{BAT}.

The current of the transmitter output stage is limited in order to protect the transmitter against short circuit to pins V_{BAT} or GND.

A loss of power (pins V_{BAT} and GND) has no impact on the bus line and the microcontroller. There are no reverse currents from the bus. The LIN transceiver can be disconnected from the power supply without influencing the LIN bus.

The output driver at pin LIN is protected against overtemperature conditions. If the junction temperature exceeds the shutdown junction temperature $T_{j(sd)}$, the thermal protection circuit disables the output driver. The driver is enabled again when the junction temperature has dropped below $T_{j(sd)}$ and a recessive level is present at pin TXD.

If V_{BAT} drops below $V_{th(VBATL)L}$, a protection circuit disables the output driver. The driver is enabled again when $V_{BAT} > V_{th(VBATL)H}$ and a recessive level is present at pin TXD.

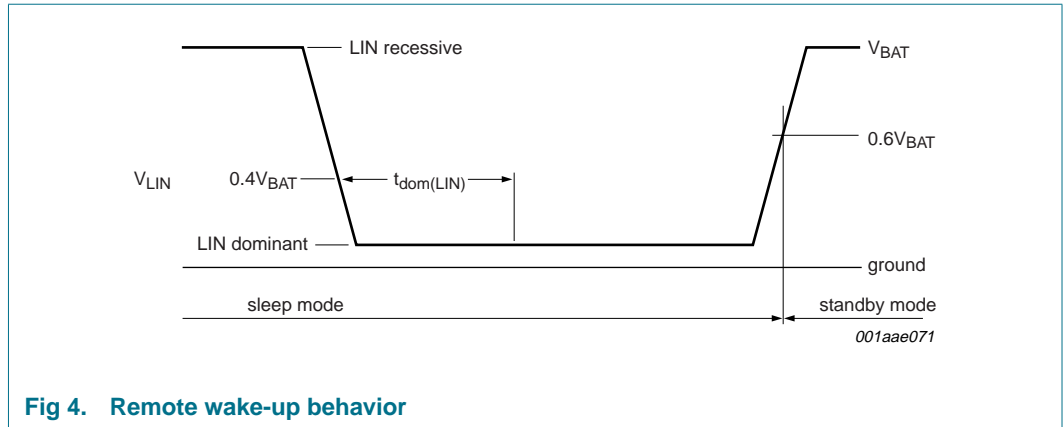

Fig 4. Remote wake-up behavior

8. Limiting values

Table 5. Limiting values

In accordance with the Absolute Maximum Rating System (IEC 60134). All voltages are referenced to pin GND; unless otherwise specified. Positive currents flow into the IC.

Symbol	Parameter	Conditions	Min	Max	Unit
V _{BAT}	supply voltage on pin V _{BAT}	with respect to GND	-0.3	+40	V
V _{TXD}	voltage on pin TXD	I _{TXD} no limitation	-0.3	+6	V
		I _{TXD} < 500 μA	-0.3	+7	V
V _{RXD}	voltage on pin RXD	I _{RXD} no limitation	-0.3	+6	V
		I _{RXD} < 500 μA	-0.3	+7	V
V _{SLP_N}	voltage on pin SLP_N	I _{SLP_N} no limitation	-0.3	+6	V
		I _{SLP_N} < 500 μA	-0.3	+7	V
V _{LIN}	voltage on pin LIN	with respect to GND, V _{BAT} and V _{WAKE_N}	-40	+40	V
V _{WAKE_N}	voltage on pin WAKE_N		-0.3	+40	V
I _{WAKE_N}	current on pin WAKE_N	only relevant if V _{WAKE_N} < V _{GND} - 0.3; current will flow into pin GND	-15	-	mA
V _{INH}	voltage on pin INH		-0.3	V _{BAT} +0.3	V
I _{O(INH)}	output current on pin INH		-50	+15	mA
T _{vj}	virtual junction temperature		[1] -40	+150	°C
T _{stg}	storage temperature		-55	+150	°C
V _{esd}	electrostatic discharge voltage				
	according to IEC 61000-4-2		[2] -	-	kV
	human body model	on pins WAKE_N, LIN, V _{BAT} and INH	[3] -8	+8	kV
		on pins RXD, SLP_N and TXD	[3] -2	+2	kV
	machine model	all pins	[4] -200	+200	V

- [1] Junction temperature in accordance with IEC 60747-1. An alternative definition is: $T_j = T_{amb} + P \times R_{th(j-a)}$, where $R_{th(j-a)}$ is a fixed value. The rating for T_{vj} limits the allowable combinations of power dissipation (P) and ambient temperature (T_{amb}).
- [2] Equivalent to discharging a 150 pF capacitor through a 330 Ω resistor. ESD performance of ± 6 kV for pins LIN, V_{BAT} and WAKE_N is verified by an external test house.
- [3] Equivalent to discharging a 100 pF capacitor through a 1.5 k Ω resistor.
- [4] Equivalent to discharging a 200 pF capacitor through a 10 Ω resistor and a 0.75 μ H coil.

9. Thermal characteristics

Table 6. Thermal characteristics

According to IEC 60747-1.

Symbol	Parameter	Conditions	Typ	Unit
$R_{th(j-a)}$	thermal resistance from junction to ambient	in SO8 package; in free air	145	K/W

10. Static characteristics

Table 7. Static characteristics

$V_{BAT} = 5.5\text{ V to }27\text{ V}$; $T_{vj} = -40\text{ }^{\circ}\text{C to }+150\text{ }^{\circ}\text{C}$; $R_{L(LIN-VBAT)} = 500\ \Omega$; all voltages are defined with respect to ground; positive currents flow into the IC; typical values are given at $V_{BAT} = 12\text{ V}$; unless otherwise specified.^[1]

Symbol	Parameter	Conditions	Min	Typ	Max	Unit
Supply						
I_{BAT}	supply current on pin V_{BAT}	sleep mode ($V_{LIN} = V_{BAT}$; $V_{WAKE_N} = V_{BAT}$; $V_{TXD} = 0\text{ V}$; $V_{SLP_N} = 0\text{ V}$)	2	7	10	μA
		standby mode; bus recessive ($V_{INH} = V_{BAT}$; $V_{LIN} = V_{BAT}$; $V_{WAKE_N} = V_{BAT}$; $V_{TXD} = 0\text{ V}$; $V_{SLP_N} = 0\text{ V}$)	150	450	1000	μA
		standby mode; bus dominant ($V_{BAT} = 12\text{ V}$; $V_{INH} = 12\text{ V}$; $V_{LIN} = 0\text{ V}$; $V_{WAKE_N} = 12\text{ V}$; $V_{TXD} = 0\text{ V}$; $V_{SLP_N} = 0\text{ V}$)	300	800	1200	μA
		normal mode; bus recessive ($V_{INH} = V_{BAT}$; $V_{LIN} = V_{BAT}$; $V_{WAKE_N} = V_{BAT}$; $V_{TXD} = 5\text{ V}$; $V_{SLP_N} = 5\text{ V}$)	300	800	1600	μA
		normal mode; bus dominant ($V_{BAT} = 12\text{ V}$; $V_{INH} = 12\text{ V}$; $V_{WAKE_N} = 12\text{ V}$; $V_{TXD} = 0\text{ V}$; $V_{SLP_N} = 5\text{ V}$)	1	2	4	mA
Power-on reset						
$V_{th(POR)L}$	LOW-level power-on reset threshold voltage	power-on reset	1.6	3.1	3.9	V
$V_{th(POR)H}$	HIGH-level power-on reset threshold voltage		2.3	3.4	4.3	V
$V_{hys(POR)}$	power-on reset hysteresis voltage		0.05	0.3	1	V
$V_{th(VBATL)L}$	LOW-level V_{BAT} LOW threshold voltage		3.9	4.4	4.7	V
$V_{th(VBATL)H}$	HIGH-level V_{BAT} LOW threshold voltage		4.2	4.7	4.9	V
$V_{hys(VBATL)}$	V_{BAT} LOW hysteresis voltage		0.05	0.3	1	V

Table 7. Static characteristics ...continued

$V_{BAT} = 5.5\text{ V to }27\text{ V}$; $T_{vj} = -40\text{ }^{\circ}\text{C to }+150\text{ }^{\circ}\text{C}$; $R_{L(LIN-VBAT)} = 500\ \Omega$; all voltages are defined with respect to ground; positive currents flow into the IC; typical values are given at $V_{BAT} = 12\text{ V}$; unless otherwise specified.^[1]

Symbol	Parameter	Conditions	Min	Typ	Max	Unit
Pin TXD						
V_{IH}	HIGH-level input voltage		2	-	7	V
V_{IL}	LOW-level input voltage		-0.3	-	+0.8	V
V_{hys}	hysteresis voltage		50	200	400	mV
$R_{PD(TXD)}$	pull-down resistance on pin TXD	$V_{TXD} = 5\text{ V}$	140	500	1200	k Ω
I_{IL}	LOW-level input current	$V_{TXD} = 0\text{ V}$	-5	-	+5	μA
I_{OL}	LOW-level output current	local wake-up request; standby mode; $V_{WAKE_N} = 0\text{ V}$; $V_{LIN} = V_{BAT}$; $V_{TXD} = 0.4\text{ V}$	1.5	-	-	mA
Pin SLP_N						
V_{IH}	HIGH-level input voltage		2	-	7	V
V_{IL}	LOW-level input voltage		-0.3	-	+0.8	V
V_{hys}	hysteresis voltage		50	200	400	mV
$R_{PD(SLP_N)}$	pull-down resistance on pin SLP_N	$V_{SLP_N} = 5\text{ V}$	140	500	1200	k Ω
I_{IL}	LOW-level input current	$V_{SLP_N} = 0\text{ V}$	-5	0	+5	μA
Pin RXD (open-drain)						
I_{OL}	LOW-level output current	normal mode; $V_{LIN} = 0\text{ V}$; $V_{RXD} = 0.4\text{ V}$	1.5	-	-	mA
I_{LH}	HIGH-level leakage current	normal mode; $V_{LIN} = V_{BAT}$; $V_{RXD} = 5\text{ V}$	-5	0	+5	μA
Pin WAKE_N						
V_{IH}	HIGH-level input voltage		$V_{BAT} - 1$	-	$V_{BAT} + 0.3$	V
V_{IL}	LOW-level input voltage		-0.3	-	$V_{BAT} - 3.3$	V
$I_{pu(L)}$	LOW-level pull-up current	$V_{WAKE_N} = 0\text{ V}$	-30	-12	-1	μA
I_{LH}	HIGH-level leakage current	$V_{WAKE_N} = 27\text{ V}$; $V_{BAT} = 27\text{ V}$	-5	0	+5	μA
Pin INH						
$R_{sw(VBAT-INH)}$	switch-on resistance between pins V_{BAT} and INH	standby; normal mode; power-on mode; $I_{INH} = -15\text{ mA}$; $V_{BAT} = 12\text{ V}$	-	20	50	Ω
I_{LH}	HIGH-level leakage current	sleep mode; $V_{INH} = 27\text{ V}$; $V_{BAT} = 27\text{ V}$	-5	0	+5	μA
Pin LIN						
I_{BUS_LIM}	current limitation for driver dominant state	$V_{BAT} = 18\text{ V}$; $V_{LIN} = 18\text{ V}$; $V_{TXD} = 0\text{ V}$	40	-	100	mA
R_{pu}	pull-up resistance	sleep mode; $V_{SLP_N} = 0\text{ V}$	50	160	250	k Ω

Table 7. Static characteristics ...continued

$V_{BAT} = 5.5\text{ V to }27\text{ V}$; $T_{vj} = -40\text{ °C to }+150\text{ °C}$; $R_{L(LIN-VBAT)} = 500\ \Omega$; all voltages are defined with respect to ground; positive currents flow into the IC; typical values are given at $V_{BAT} = 12\text{ V}$; unless otherwise specified.^[1]

Symbol	Parameter	Conditions	Min	Typ	Max	Unit
$I_{BUS_PAS_rec}$	receiver recessive input leakage current	$V_{LIN} = 27\text{ V}$; $V_{BAT} = 5.5\text{ V}$; $V_{TXD} = 5\text{ V}$	-	-	1	μA
$I_{BUS_PAS_dom}$	receiver dominant input leakage current including pull-up resistor	normal mode; $V_{TXD} = 5\text{ V}$; $V_{LIN} = 0\text{ V}$; $V_{BAT} = 12\text{ V}$	-600	-	-	μA
$V_{SerDiode}$	voltage drop at the serial diodes	in pull-up path with R_{slave} $I_{SerDiode} = 10\text{ mA}$	^{[2][3]} 0.4	-	1.0	V
$I_{L(log)}$	loss of ground leakage current	$V_{BAT} = 27\text{ V}$; $V_{LIN} = 0\text{ V}$	-750	-	+10	μA
$I_{L(lob)}$	loss of battery leakage current	$V_{BAT} = 0\text{ V}$; $V_{LIN} = 27\text{ V}$	-	-	1	μA
$V_{th(dom)RX}$	receiver dominant threshold voltage		-	-	$0.4V_{BAT}$	V
$V_{th(rec)RX}$	receiver recessive threshold voltage		$0.6V_{BAT}$	-	-	V
$V_{th(RX)cntr}$	center receiver threshold voltage	$V_{th(RX)AV} =$ $(V_{th(rec)RX} + V_{th(dom)RX}) / 2$	$0.475V_{BAT}$	$0.5V_{BAT}$	$0.525V_{BAT}$	V
$V_{th(hys)RX}$	receiver hysteresis threshold voltage	$V_{th(hys)RX} =$ $V_{th(rec)RX} - V_{th(dom)RX}$	-	-	$0.175V_{BAT}$	V
R_{slave}	slave resistance	connected between pins LIN and V_{BAT} ; $V_{LIN} = 0\text{ V}$; $V_{BAT} = 12\text{ V}$	20	30	47	$\text{k}\Omega$
C_{LIN}	capacitance on pin LIN		^{[2][3]} -	-	30	pF
$V_{o(dom)}$	dominant output voltage	normal mode; $V_{TXD} = 0\text{ V}$; $V_{BAT} = 7.0\text{ V}$	-	-	1.4	V
		normal mode; $V_{TXD} = 0\text{ V}$; $V_{BAT} = 18\text{ V}$	-	-	2.0	V
Thermal shutdown						
$T_{j(sd)}$	shutdown junction temperature		^{[2][3]} 150	175	200	$^{\circ}\text{C}$

[1] All parameters are guaranteed by design over the virtual junction temperature range. Products are 100 % tested at 125 °C ambient temperature on wafer level (pre-testing). Cased products are 100 % tested at 25 °C ambient temperature (final testing). Both pre-testing and final testing use correlated test conditions to cover the specified temperature and power supply voltage range.

[2] Guaranteed by design.

[3] Not tested.

11. Dynamic characteristics

Table 8. Dynamic characteristics

$V_{BAT} = 5.5\text{ V to }18\text{ V}$; $T_{vj} = -40\text{ }^{\circ}\text{C to }+150\text{ }^{\circ}\text{C}$; $R_{L(LIN-VBAT)} = 500\text{ }\Omega$; all voltages are defined with respect to ground; positive currents flow into the IC; typical values are given at $V_{BAT} = 12\text{ V}$; see [Figure 5](#); unless otherwise specified.^[1]

Symbol	Parameter	Conditions	Min	Typ	Max	Unit	
Duty cycles							
$\delta 1$	duty cycle 1	$V_{th(rec)(max)} = 0.744 \times V_{BAT}$; $V_{th(dom)(max)} = 0.581 \times V_{BAT}$; $t_{bit} = 50\text{ }\mu\text{s}$; $V_{BAT} = 7\text{ V to }18\text{ V}$	[2][3][4] 7]	0.396	-	-	
		$V_{th(rec)(max)} = 0.76 \times V_{BAT}$; $V_{th(dom)(max)} = 0.593 \times V_{BAT}$; $t_{bit} = 50\text{ }\mu\text{s}$; $V_{BAT} = 5.5\text{ V to }7.0\text{ V}$	[2][3][4] 7]	0.396	-	-	
$\delta 2$	duty cycle 2	$V_{th(rec)(min)} = 0.422 \times V_{BAT}$; $V_{th(dom)(min)} = 0.284 \times V_{BAT}$; $t_{bit} = 50\text{ }\mu\text{s}$; $V_{BAT} = 7.6\text{ V to }18\text{ V}$	[2][4][5] 7]	-	-	0.581	
		$V_{th(rec)(min)} = 0.41 \times V_{BAT}$; $V_{th(dom)(min)} = 0.275 \times V_{BAT}$; $t_{bit} = 50\text{ }\mu\text{s}$; $V_{BAT} = 6.1\text{ V to }7.6\text{ V}$	[2][4][5] 7]	-	-	0.581	
$\delta 3$	duty cycle 3	$V_{th(rec)(max)} = 0.778 \times V_{BAT}$; $V_{th(dom)(max)} = 0.616 \times V_{BAT}$; $t_{bit} = 96\text{ }\mu\text{s}$; $V_{BAT} = 7\text{ V to }18\text{ V}$	[3][4][7]	0.417	-	-	
		$V_{th(rec)(max)} = 0.797 \times V_{BAT}$; $V_{th(dom)(max)} = 0.630 \times V_{BAT}$; $t_{bit} = 96\text{ }\mu\text{s}$; $V_{BAT} = 5.5\text{ V to }7\text{ V}$	[3][4][7]	0.417	-	-	
$\delta 4$	duty cycle 4	$V_{th(rec)(min)} = 0.389 \times V_{BAT}$; $V_{th(dom)(min)} = 0.251 \times V_{BAT}$; $t_{bit} = 96\text{ }\mu\text{s}$; $V_{BAT} = 7.6\text{ V to }18\text{ V}$	[4][5][7]	-	-	0.590	
		$V_{th(rec)(min)} = 0.378 \times V_{BAT}$; $V_{th(dom)(min)} = 0.242 \times V_{BAT}$; $t_{bit} = 96\text{ }\mu\text{s}$; $V_{BAT} = 6.1\text{ V to }7.6\text{ V}$	[4][5][7]	-	-	0.590	
Timing characteristics							
t_f	fall time		[2][4]	-	-	22.5	μs
t_r	rise time		[2][4]	-	-	22.5	μs
$\Delta t_{(r-f)}$	difference between rise and fall time	$V_{BAT} = 7.3\text{ V}$	[2][4]	-5	-	+5	μs
$t_{PD(TX)}$	transmitter propagation delay		[2]	-	-	6	μs
$t_{PD(TX)sym}$	transmitter propagation delay symmetry			-2.5	-	+2.5	μs

Table 8. Dynamic characteristics ...continued

$V_{BAT} = 5.5\text{ V to }18\text{ V}$; $T_{vj} = -40\text{ }^{\circ}\text{C to }+150\text{ }^{\circ}\text{C}$; $R_{L(LIN-VBAT)} = 500\ \Omega$; all voltages are defined with respect to ground; positive currents flow into the IC; typical values are given at $V_{BAT} = 12\text{ V}$; see [Figure 5](#); unless otherwise specified.^[1]

Symbol	Parameter	Conditions	Min	Typ	Max	Unit
$t_{PD(RX)}$	receiver propagation delay		[6] -	-	6	μs
$t_{PD(RX)sym}$	receiver propagation delay symmetry		[6] -2	-	+2	μs
$t_{wake(dom)LIN}$	dominant wake-up time on pin LIN	sleep mode	30	80	150	μs
$t_{wake(dom)WAKE_N}$	dominant wake-up time on pin WAKE_N	sleep mode	7	30	50	μs
$t_{gotonorm}$	go to normal time	time period for mode change from sleep, power-on or standby mode into normal mode	2	5	10	μs
$t_{init(norm)}$	normal mode initialization time		5	-	20	μs
$t_{gotosleep}$	go to sleep time	time period for mode change from normal slope mode into sleep mode	2	5	10	μs
$t_{to(dom)TXD}$	TXD dominant time-out time	$V_{TXD} = 0\text{ V}$	27	55	90	ms

[1] All parameters are guaranteed by design over the virtual junction temperature range. Products are 100 % tested at 125 °C ambient temperature on wafer level (pre-testing). Cased products are 100 % tested at 25 °C ambient temperature (final testing). Both pre-testing and final testing use correlated test conditions to cover the specified temperature and power supply voltage range.

[2] Not applicable for the /10 version of the TJA1021.

[3] $\delta 1, \delta 3 = \frac{t_{bus(rec)(min)}}{2 \times t_{bit}}$

[4] Bus load conditions are: $C_L = 1\text{ nF}$ and $R_L = 1\text{ k}\Omega$; $C_L = 6.8\text{ nF}$ and $R_L = 660\ \Omega$; $C_L = 10\text{ nF}$ and $R_L = 500\ \Omega$.

[5] $\delta 2, \delta 4 = \frac{t_{bus(rec)(max)}}{2 \times t_{bit}}$

[6] Load condition pin RXD: $C_{RXD} = 20\text{ pF}$ and $R_{RXD} = 2.4\text{ k}\Omega$.

[7] For $V_{BAT} > 18\text{ V}$ the LIN transmitter might be suppressed. If TXD is HIGH then the LIN transmitter output is recessive.

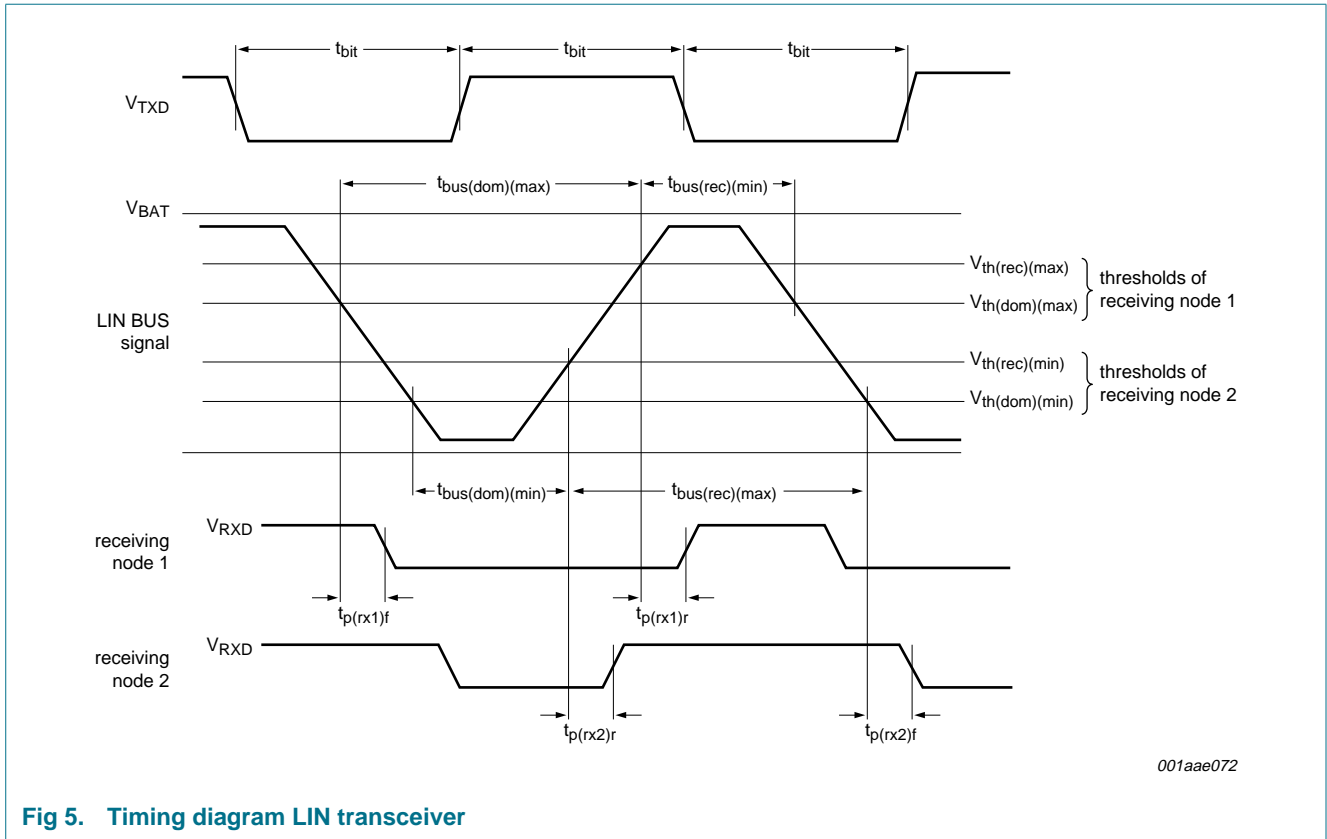
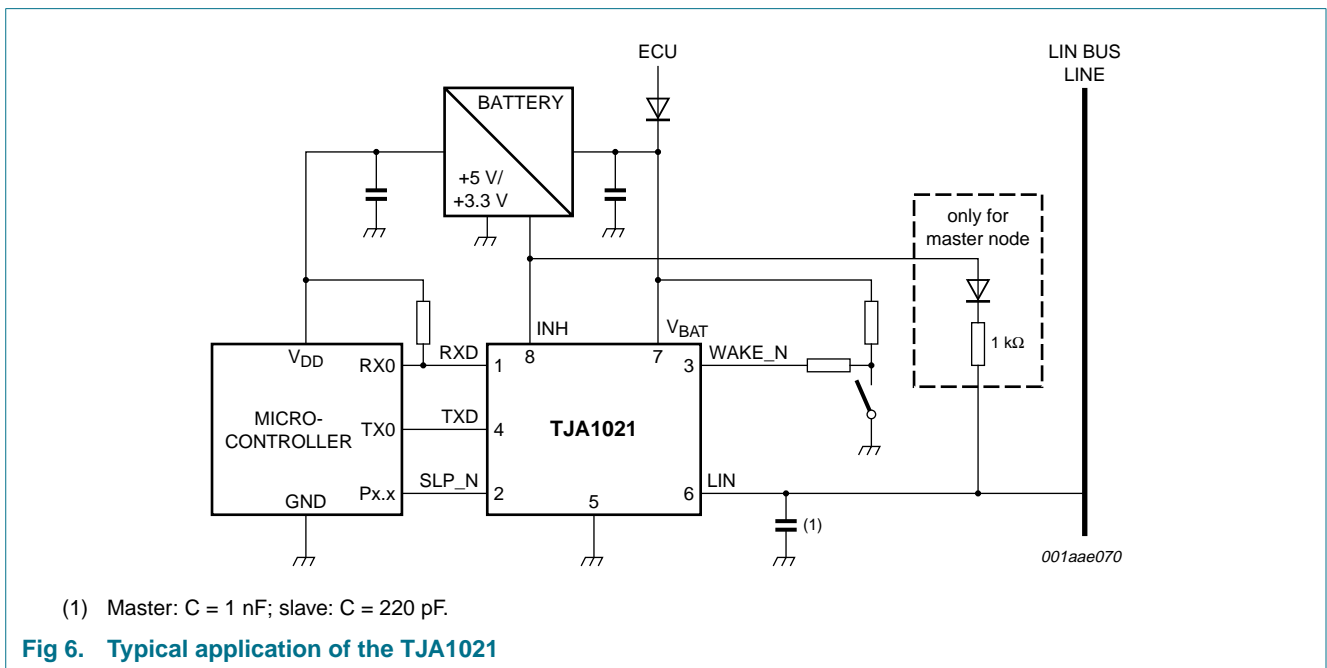

Fig 5. Timing diagram LIN transceiver

12. Application information



(1) Master: C = 1 nF; slave: C = 220 pF.

Fig 6. Typical application of the TJA1021

13. Test information

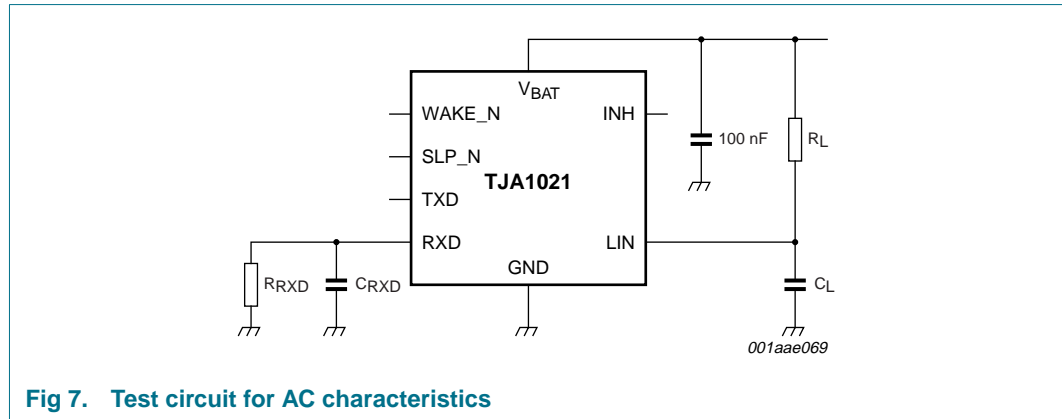

Immunity against automotive transients (malfunction and damage) in accordance with LIN EMC Test Specification / Version 1.0; August 1, 2004.

The waveforms of the applied transients are according to ISO7637-2: Draft 2002-12, test pulses 1, 2a, 3a and 3b.

13.1 Quality information

This product has been qualified to the appropriate Automotive Electronics Council (AEC) standard Q100 or Q101 and is suitable for use in automotive critical applications.

14. Package outline

SO8: plastic small outline package; 8 leads; body width 3.9 mm

SOT96-1

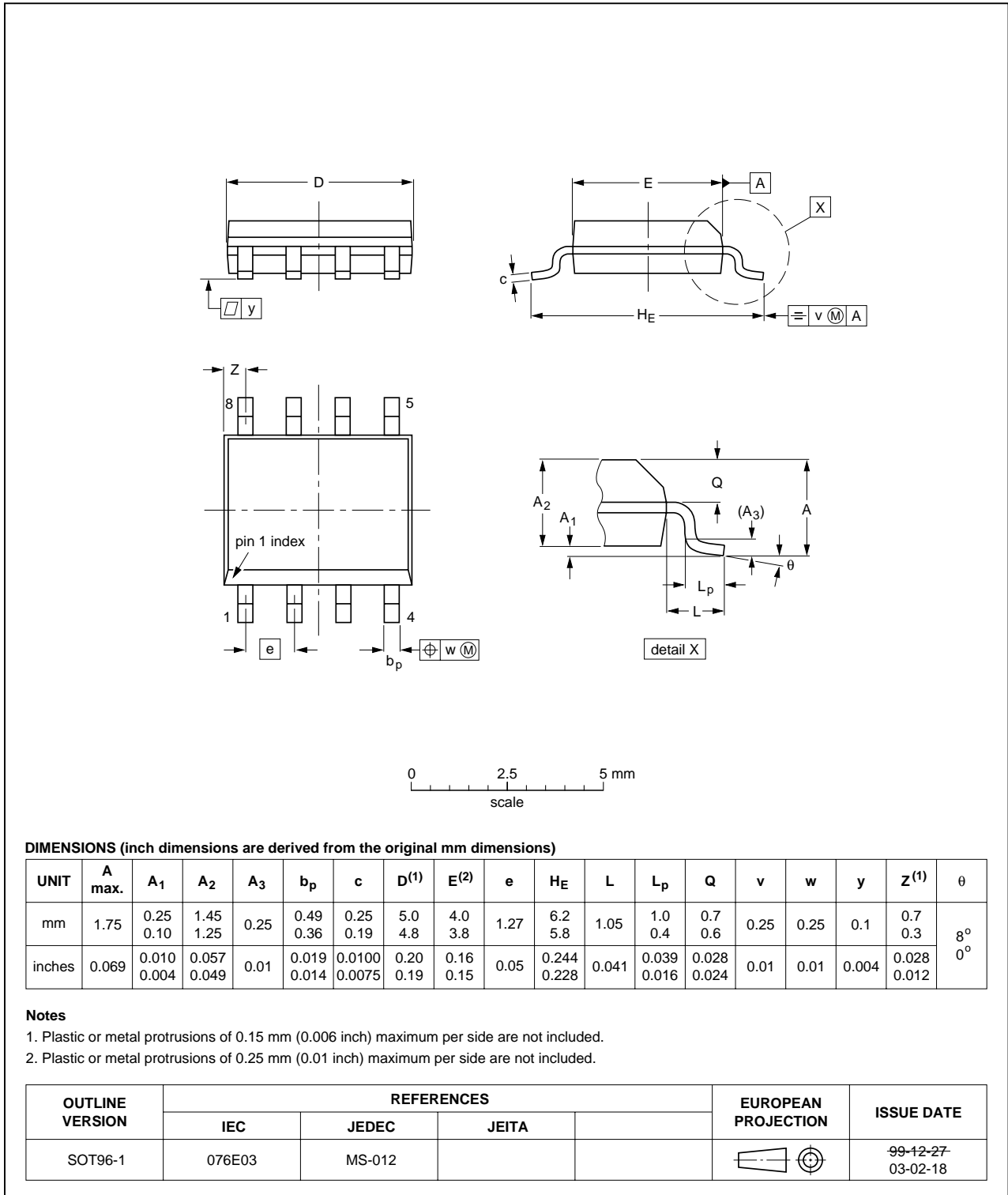

Fig 8. Package outline SOT96-1 (SO8)

15. Handling information

Inputs and outputs are protected against electrostatic discharge in normal handling. However, to be completely safe you must take normal precautions appropriate to handling integrated circuits.

16. Soldering

This text provides a very brief insight into a complex technology. A more in-depth account of soldering ICs can be found in Application Note *AN10365 "Surface mount reflow soldering description"*.

16.1 Introduction to soldering

Soldering is one of the most common methods through which packages are attached to Printed Circuit Boards (PCBs), to form electrical circuits. The soldered joint provides both the mechanical and the electrical connection. There is no single soldering method that is ideal for all IC packages. Wave soldering is often preferred when through-hole and Surface Mount Devices (SMDs) are mixed on one printed wiring board; however, it is not suitable for fine pitch SMDs. Reflow soldering is ideal for the small pitches and high densities that come with increased miniaturization.

16.2 Wave and reflow soldering

Wave soldering is a joining technology in which the joints are made by solder coming from a standing wave of liquid solder. The wave soldering process is suitable for the following:

- Through-hole components
- Leaded or leadless SMDs, which are glued to the surface of the printed circuit board

Not all SMDs can be wave soldered. Packages with solder balls, and some leadless packages which have solder lands underneath the body, cannot be wave soldered. Also, leaded SMDs with leads having a pitch smaller than ~0.6 mm cannot be wave soldered, due to an increased probability of bridging.

The reflow soldering process involves applying solder paste to a board, followed by component placement and exposure to a temperature profile. Leaded packages, packages with solder balls, and leadless packages are all reflow solderable.

Key characteristics in both wave and reflow soldering are:

- Board specifications, including the board finish, solder masks and vias
- Package footprints, including solder thieves and orientation
- The moisture sensitivity level of the packages
- Package placement
- Inspection and repair
- Lead-free soldering versus PbSn soldering

16.3 Wave soldering

Key characteristics in wave soldering are:

- Process issues, such as application of adhesive and flux, clinching of leads, board transport, the solder wave parameters, and the time during which components are exposed to the wave
- Solder bath specifications, including temperature and impurities

16.4 Reflow soldering

Key characteristics in reflow soldering are:

- Lead-free versus SnPb soldering; note that a lead-free reflow process usually leads to higher minimum peak temperatures (see [Figure 9](#)) than a PbSn process, thus reducing the process window
- Solder paste printing issues including smearing, release, and adjusting the process window for a mix of large and small components on one board
- Reflow temperature profile; this profile includes preheat, reflow (in which the board is heated to the peak temperature) and cooling down. It is imperative that the peak temperature is high enough for the solder to make reliable solder joints (a solder paste characteristic). In addition, the peak temperature must be low enough that the packages and/or boards are not damaged. The peak temperature of the package depends on package thickness and volume and is classified in accordance with [Table 9](#) and [10](#)

Table 9. SnPb eutectic process (from J-STD-020C)

Package thickness (mm)	Package reflow temperature (°C)	
	Volume (mm ³)	
	< 350	≥ 350
< 2.5	235	220
≥ 2.5	220	220

Table 10. Lead-free process (from J-STD-020C)

Package thickness (mm)	Package reflow temperature (°C)		
	Volume (mm ³)		
	< 350	350 to 2000	> 2000
< 1.6	260	260	260
1.6 to 2.5	260	250	245
> 2.5	250	245	245

Moisture sensitivity precautions, as indicated on the packing, must be respected at all times.

Studies have shown that small packages reach higher temperatures during reflow soldering, see [Figure 9](#).

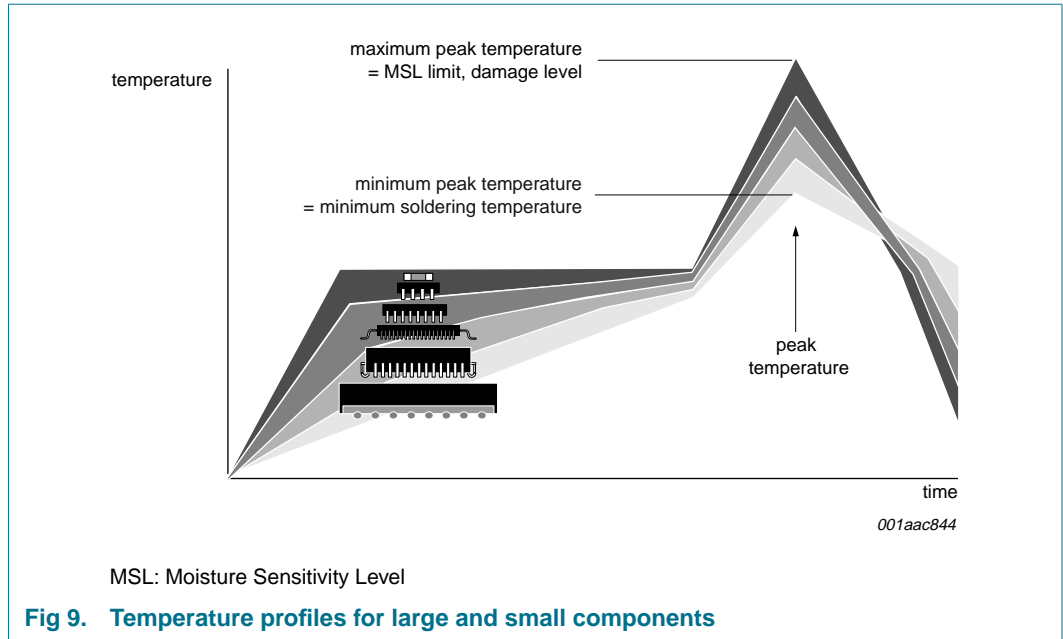

For further information on temperature profiles, refer to Application Note AN10365 "Surface mount reflow soldering description".

17. Revision history

Table 11. Revision history

Document ID	Release date	Data sheet status	Change notice	Supersedes
TJA1021_3	20071008	Product data sheet	-	TJA1021_2
Modifications:	<ul style="list-style-type: none"> • Status changed from Preliminary data sheet to Product data sheet • Table 1: I_{BAT} values updated • Bonding pad description table removed • Section 7: Introductory text updated • Table 4: Table notes updated • Section 7.2: Updated • Section 7.3: Updated • Section 7.5: Updated • Section 7.6: Updated • Table 5: Updated • Table 6: Updated • Table 7: Updated • Table 8: Updated 			
TJA1021_2	-	Preliminary data sheet	-	TJA1021_1
TJA1021_1	20061016	Objective data sheet	-	-

18. Legal information

18.1 Data sheet status

Document status ^{[1][2]}	Product status ^[3]	Definition
Objective [short] data sheet	Development	This document contains data from the objective specification for product development.
Preliminary [short] data sheet	Qualification	This document contains data from the preliminary specification.
Product [short] data sheet	Production	This document contains the product specification.

[1] Please consult the most recently issued document before initiating or completing a design.

[2] The term 'short data sheet' is explained in section "Definitions".

[3] The product status of device(s) described in this document may have changed since this document was published and may differ in case of multiple devices. The latest product status information is available on the Internet at URL <http://www.nxp.com>.

18.2 Definitions

Draft — The document is a draft version only. The content is still under internal review and subject to formal approval, which may result in modifications or additions. NXP Semiconductors does not give any representations or warranties as to the accuracy or completeness of information included herein and shall have no liability for the consequences of use of such information.

Short data sheet — A short data sheet is an extract from a full data sheet with the same product type number(s) and title. A short data sheet is intended for quick reference only and should not be relied upon to contain detailed and full information. For detailed and full information see the relevant full data sheet, which is available on request via the local NXP Semiconductors sales office. In case of any inconsistency or conflict with the short data sheet, the full data sheet shall prevail.

18.3 Disclaimers

General — Information in this document is believed to be accurate and reliable. However, NXP Semiconductors does not give any representations or warranties, expressed or implied, as to the accuracy or completeness of such information and shall have no liability for the consequences of use of such information.

Right to make changes — NXP Semiconductors reserves the right to make changes to information published in this document, including without limitation specifications and product descriptions, at any time and without notice. This document supersedes and replaces all information supplied prior to the publication hereof.

Suitability for use — NXP Semiconductors products are not designed, authorized or warranted to be suitable for use in medical, military, aircraft, space or life support equipment, nor in applications where failure or malfunction of a NXP Semiconductors product can reasonably be expected to result in personal injury, death or severe property or environmental damage. NXP Semiconductors accepts no liability for inclusion and/or use of NXP Semiconductors products in such equipment or applications and therefore such inclusion and/or use is at the customer's own risk.

Applications — Applications that are described herein for any of these products are for illustrative purposes only. NXP Semiconductors makes no representation or warranty that such applications will be suitable for the specified use without further testing or modification.

Limiting values — Stress above one or more limiting values (as defined in the Absolute Maximum Ratings System of IEC 60134) may cause permanent damage to the device. Limiting values are stress ratings only and operation of the device at these or any other conditions above those given in the Characteristics sections of this document is not implied. Exposure to limiting values for extended periods may affect device reliability.

Terms and conditions of sale — NXP Semiconductors products are sold subject to the general terms and conditions of commercial sale, as published at <http://www.nxp.com/profile/terms>, including those pertaining to warranty, intellectual property rights infringement and limitation of liability, unless explicitly otherwise agreed to in writing by NXP Semiconductors. In case of any inconsistency or conflict between information in this document and such terms and conditions, the latter will prevail.

No offer to sell or license — Nothing in this document may be interpreted or construed as an offer to sell products that is open for acceptance or the grant, conveyance or implication of any license under any copyrights, patents or other industrial or intellectual property rights.

Bare die — All die are tested on compliance with all related technical specifications as stated in this data sheet up to the point of wafer sawing for a period of ninety (90) days from the date of delivery by NXP Semiconductors. If there are data sheet limits not guaranteed, these will be separately indicated in the data sheet. There are no post-packing tests performed on individual die or wafers.

NXP Semiconductors has no control of third party procedures in the sawing, handling, packing or assembly of the die. Accordingly, NXP Semiconductors assumes no liability for device functionality or performance of the die or systems after third party sawing, handling, packing or assembly of the die. It is the responsibility of the customer to test and qualify their application in which the die is used.

All die sales are conditioned upon and subject to the customer entering into a written die sale agreement with NXP Semiconductors through its legal department.

18.4 Trademarks

Notice: All referenced brands, product names, service names and trademarks are the property of their respective owners.

19. Contact information

For additional information, please visit: <http://www.nxp.com>

For sales office addresses, send an email to: salesaddresses@nxp.com

20. Contents

1	General description	1
2	Features	1
2.1	General	1
2.2	Low power management	1
2.3	Protections	1
3	Quick reference data	2
4	Ordering information	3
5	Block diagram	3
6	Pinning information	4
6.1	Pinning	4
6.2	Pin description	4
7	Functional description	4
7.1	Operating modes	4
7.2	Sleep mode	6
7.3	Standby mode	6
7.4	Normal mode	7
7.5	Wake-up	7
7.6	Remote and local wake-up	7
7.7	Wake-up via mode transition	7
7.8	Wake-up source recognition	8
7.9	TXD dominant time-out function	8
7.10	Fail-safe features	8
8	Limiting values	9
9	Thermal characteristics	10
10	Static characteristics	11
11	Dynamic characteristics	14
12	Application information	16
13	Test information	17
13.1	Quality information	17
14	Package outline	18
15	Handling information	19
16	Soldering	19
16.1	Introduction to soldering	19
16.2	Wave and reflow soldering	19
16.3	Wave soldering	19
16.4	Reflow soldering	20
17	Revision history	22
18	Legal information	23
18.1	Data sheet status	23
18.2	Definitions	23
18.3	Disclaimers	23
18.4	Trademarks	23
19	Contact information	23
20	Contents	24

Please be aware that important notices concerning this document and the product(s) described herein, have been included in section 'Legal information'.

founded by

PHILIPS

© NXP B.V. 2007.

All rights reserved.

For more information, please visit: <http://www.nxp.com>

For sales office addresses, please send an email to: salesaddresses@nxp.com

Date of release: 8 October 2007

Document identifier: TJA1021_3